

BAMBINA

Pedal operated nappy bin



BAMBINA is a 50 litre pedal operated nappy bin with a built in odour control system. Developed in response to market demand for a robust and aesthetically pleasing pedal operated bin, BAMBINA incorporates a host of practical service and user friendly features.

The unit has a large waste holding capacity while remaining compact, modern and attractive in design. It is pedal operated to ensure maximum hygiene and has a unique built in odour control system which makes the end user experience more pleasant.

BAMBINA incorporates a removable hygienic bin to aid serviceability. The hygienic bin protects the inside of the unit from soiling and can be removed for easy cleaning.



Finishes available

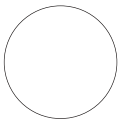

Classic White

Benefits

Ease of service

- > Removable hygienic bin protects bin from soiling/eases cleaning
- > Designed throughout to minimise dirt traps

Maximum hygiene

- > Foot pedal for hands-free operation
- > Removable hygienic bin
 - Protects inside of bin from soiling
 - Removes for easy bin cleaning

For extra hygiene

- > Nappy bin liners
- > Germicidal powder sachets
 - Inhibit microbial growth
 - Prevent offensive odour

End user satisfaction & Image

- > Built in odour control system
- > Large centrally positioned aperture for easy nappy disposal
- > Modesty flap ensures waste inside is not visible
- > Compact, modern and attractive design

For more information
www.kennedy-hygiene.co.uk

BAMBINA

Pedal operated nappy bin



Packaging info

| | Plt.Type | Packed | Qty Per | Weight/Kg | Measurement in cm |
|---------|-----------------|---------------|----------------|------------------|--------------------------|
| BAMBINA | | Carton | 1 | 6 | 44 x 37.5 x 53 |
| | Std. Plt | Pallet | 18 | 113 | 120 x 100 x 200 |

Technical drawings

Materials: Constructed mainly from ABS. Dispenser can be recycled or disposed of in accordance with local regulations.

Packing: One unit is packed into a double wall carton.

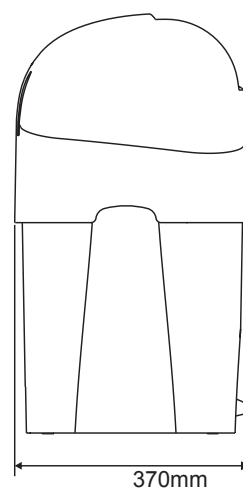
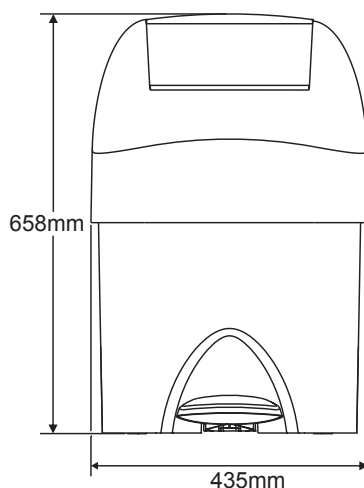

Consumables

Nappy bin liners

Germicidal powder sachets

- > Inhibit microbial growth
- > Prevent offensive odour

Kennedy Hygiene Products Limited

Brookside

Uckfield

East Sussex TN22 1YA

United Kingdom

T +44 (0) 1825 768141

F +44 (0) 1825 768143

E sales@kennedy-hygiene.com

